

Kamco

KAMCO Limited
Unit 9, Curo Park
Frogmore
St. Albans
HERTS AL2 2DD - UK

Telephone: 01727 875020
Facsimile: 01727 875335

info@kamco.co.uk
www.kamco.co.uk



The Power Flushing Knowledge Base

Frequently asked questions,
and their answers

INDEX

Adding corrosion inhibitor	Page 15	Over pressurising a system?	Page 6
Aluminium heat exchangers-FX2	Page 6	Plastic piping, barrier type	Page 11
Artificially softened water	Page 16	Plastic piping, non-barrier	Page 11
Best chemical for old systems	Page 7	Poor mains water flow rate	Page 14
Bleeding radiators after a flush	Page 14	PowerFlush FX2-leaving in system?	Page 6
Blocked cold feed pipe-check?	Page 6	PowerFlush FX2-Neutralising	Page 6
Blocked radiator & piping tips	Page 14	Primatic single feed cylinders	Page 10
Boiler noises	Page 4	Push fit connections	Page 5
Checking system water is clean	Page 15	RadHammer vibrator	Page 4
Clearflow tank overflowing?	Page 13	Radiators staying cool at top	Page 13
Cold feed & expansion tank	Page 3	Radiators staying hot at the top	Page 13
Combi boiler won't fire	Page 8	Reducing time for a power flush	Page 15
CombiMag Dual power flush heater	Page 8	Septic tanks & power flushing	Page 12
Corrosion inhibitor-level checking	Page 7	Servicing Kamco pumps	Page 16
Damaging a heating system??	Page 17	Single pipe systems	Page 10
Deposit inside copper pipe?	Page 6	Systems to avoid flushing	Page 11
Discharging very hot water	Page 9	Temperature limitation	Page 9
Double panel radiators	Page 4	Thermal store cylinders	Page 5
Expansion vessel	Page 3	Thermostatic radiator valves	Page 6
Extension hoses	Page 5	Things NOT to do	Page 15
Filling loop, do not use	Page 16	Underfloor heating	Page 11
Firing the boiler during a power flush	Page 7	Underfloor heating, bacterial growth	Page 11
Flushing radiators after removal	Page 5	Vibrating radiators	Page 4
Gas Safe Registration	Page 3	Volume of a heating system	Page 4
Gravity hot water systems	Page 10		
Guaranteed cleanliness?	Page 17		
How long does a power flush take?	Page 3		
How long will a power flush last?	Page 17		
Imperial size pipework	Page 5		
Individual radiator dumping	Page 14		
Individual radiator flushing	Page 14		
Inhibitor used with soft water	Page 16		
Location of flushing pump	Page 5		
Microbore systems	Page 9/10		
Mixing different inhibitors	Page 7		
No flow in one direction	Page 13		

Frequently asked questions about the use of Clearflow power flushing pumps

General questions; planning, and 'before you start'.

Q. How long does it take to power flush a system thoroughly?

A. It will vary from house to house, but generally about 5+ hours for a three bed house with a vented system, but less time for a sealed / combination boiler system, because you don't have to cap off the cold feed and expansion piping.

You can save more time by using a CP2 pump head adaptor to get connected faster, and also by filtering the water as you go with a CombiMag power flush filter.

Q. How big a heating system can you use a Clearflow pump on?

A. Obviously this will depend on what model Clearflow you have. If you have a CF30 Classic, then you can tackle systems up to 20 radiators with the right technique. Follow the normal procedures for systems up to 12 radiators, but tackle larger systems in sections. For example, with a twenty radiator system, close off ten radiators totally, and flush the rest of the house normally. Once done, close down all the flushed radiators, and repeat the procedure on the rest of the system. The CF40 Evolution has a significantly higher flow rate, and so up to 25 radiators is a reasonable prospect, and larger if you section the system.

If you regularly work on larger systems, you'll really appreciate the extra performance of a CF90 Quantum2, which will get more debris from any given system (even a small microbore one!)

Q. Do you need to drain down the system before you start?

A. No. You only need to run some water out of a vented system to lower the water level in the feed and expansion tank, so that you can cap it off.

Q. Can you power flush a sealed system?

A. You certainly can - in fact you can ONLY power flush a sealed system. Why do we say that? because any system that you power flush must be sealed (even if that is for the duration of the power flush only in the case of a vented system).

That is why you must 'cap off' the cold feed and expansion pipes of systems that AREN'T already sealed,

to prevent the high flow of water of a good power flushing pump from forcing water up into the f&e tank and overwhelming the tank overflow. Naturally you remove the temporary caps after you've flushed the

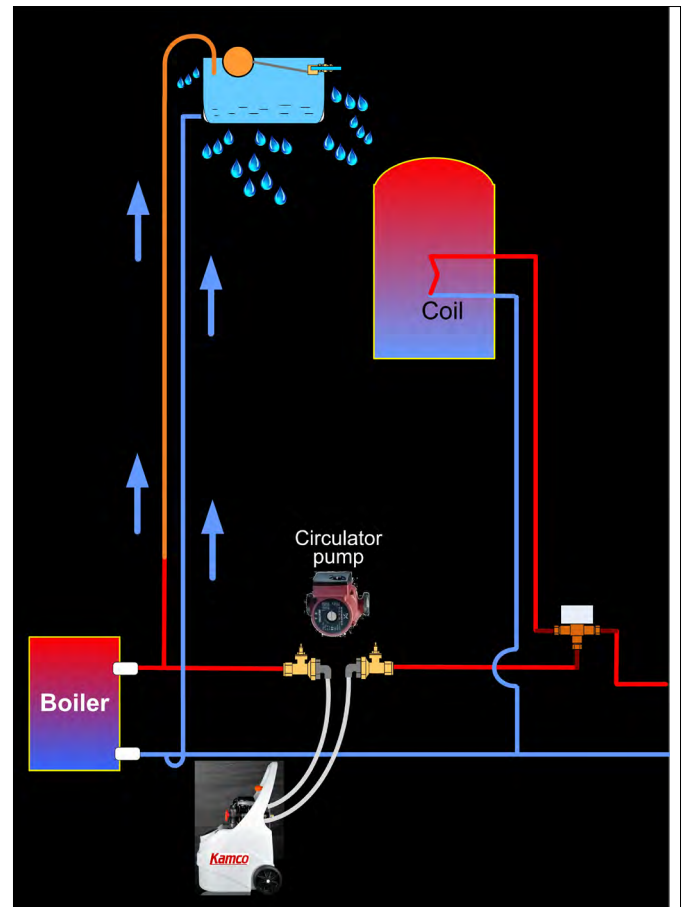

system.

Obviously you don't have a vent or cold feed pipe to cap off with a sealed system, and so the power flush won't take so long. When you break into the sealed system wherever you have chosen to connect your power flushing pump, you'll lose the normal system operating pressure, and will have to re-pressurise the system with the filling loop after you've finished the flush.

Q. If I power flush a sealed system, which has a pressure/expansion vessel, do I need to take any special precautions or disconnect it?

A. No, not if you are using Kamco flushing chemicals. They will not cause any problems with the diaphragm of an expansion vessel.

Q. Do you need to be Gas Safe registered to power flush heating systems?

A. You don't have to be Gas Safe registered to power flush a heating system. As long as you are NOT working on the gas train, then you don't need approval, BUT be

careful if you use the CP2 adapter on some combination boilers.

Obviously you have to take the boiler case off to fit the CP2 adapter on to the pump body located within the boiler casing. If the boiler case is 'sealed', i.e. it is part of the combustion air inlet system, then you do need to be Gas Safe registered ##.

If the case is only decorative, then you don't.

In this case, and you are not Gas Safe registered, you'd probably connect the Clearflow pump across the tails of one radiator, after having first removed it.

Q. How do I know how much water is in a system, particularly larger ones, so that I can add the correct amount of flushing chemical?

A. It's always tricky to estimate the amount of water in a larger system (and no-one ever can tell you from existing records), and so the industry 'rule of thumb' guide is to multiply the boiler output, expressed in kW, by 12, and that gives an approximate figure, in litres.

For smaller systems, then assume that 10 radiators (or radiator panels) is close to 100 litres. More modern systems frequently contain less water, but it's always better to add too much chemical than too little.

Q. Will power flushing cure boiler noises?

A. Boiler noises are often caused by scale or debris accumulating on heat transfer surfaces, thus preventing the water from carrying away heat from the metal

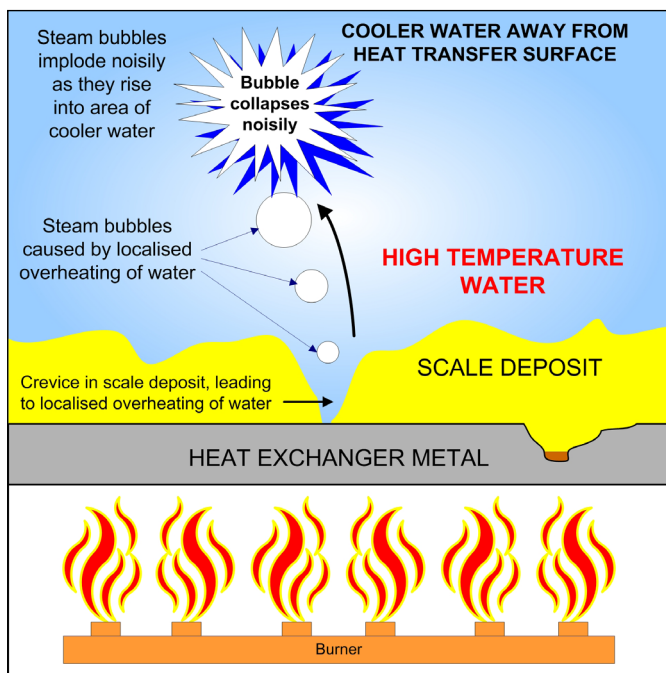

surface. This means that the metal runs hotter than design temperature and may even exceed 100 degrees C. The layer of scale / debris is never even, and there will

be areas where the water contacts metal above 100 degrees. At this temperature water flashes into steam, increasing its volume by almost 1500 times. The steam bubbles then move away from the high temperature zone and collapse and it is the sound of the implosion of the steam bubble that you hear. This phenomenon is most likely to occur when the boiler first fires and is working hard.

It is a reasonable assumption that if you can remove the debris / scale (and you usually can when power flushing) that you will remove the problem.

Having said that, we know that boilers with cast iron heat exchangers can acquire corrosion pits as they age, generally if the water treatment has been inadequate. In these areas, where the heat exchanger metal is reduced in thickness, the heat flux can be higher than the designer intended, and there can still be boiler noises no matter how clean the heat transfer surface may be after a power flush.

Q. What about double panel radiators - won't the water take the course of least resistance and just clear one panel?

A. Yes, it will. However, whilst carrying out the individual radiator flush, gently tap the front panel with a rubber mallet, where the brackets attach to the rear panel. There will always be at least four points of connection, at the ends, top and bottom. This vibrates debris loose with surprisingly good effect.

An even better method is to use a Radhammer vibrator device, also supplied by Kamco. This device clicks into the chuck of an SDS drill which has been set to 'hammer only'. The high frequency vibration will loosen debris that will not respond to other cleansing methods.



Q. Is it a good idea to tap radiators whilst carrying out a power flush?

A. Yes. Many engineers tap every radiator along the lower edge with a mallet as they open it up for the individual radiator flush, to vibrate loose any compacted sludge trapped in the bottom seam. The Kamco RadHammer is even more effective, and a brief application of the RadHammer after you have what is apparently already got clear water running through a radiator can give surprising results!

Q. Can I use a radiator valve change kit (= tapered rubber bung kit), used when changing radiators, to make the system a closed circuit for the power flush?

A. No. The tapered bung inserted in the cold feed pipe will be forced out, and the expansion tank will fill up and overflow.

Q. Can I use plastic or metal push fit caps, such as "Speedfit" fittings, to make the system a closed circuit?

A. Yes, but check the push fit cap 'O' ring for wear regularly, and replace it if in doubt.

Q. What do I do if the expansion pipe on an old system is imperial size copper piping?

A. Why not extend the pipe slightly, using a compression fitting with a special imperial size olive, enabling you to add a short length of metric piping? Then use a push fit end cap as usual.

Q. If I connect my Clearflow pump into the system across the tails of one (removed) radiator, what happens to that radiator? How should I clean it?

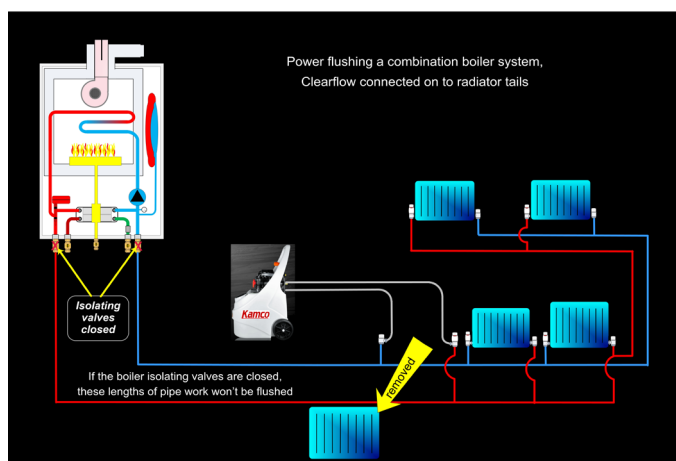

A. You'll need to flush this separately with a hose pipe (so pick a small radiator!).

Alternatively, some engineers will adapt the outer end of their dump hose to fit onto one side of this removed radiator, with another adapted tube leading from the other side of the radiator to the drain.

This way, every time you dump, you're putting a good flow of water through the radiator. By the time you've finished the power flush, the radiator should be very clean.

Q. I want to keep my pump outside the house. Can I use extension hoses?

A. Yes you can, and we can supply any length extensions that you may wish, but we often supply an extra set of 5 metre flow and return hoses, and send them out with a 3/4" - 3/4" male nipple in one end of each hose.

This means that when you need to extend flow and return hoses, you simply couple the new extension hoses onto your existing flow and return hoses, and if you sometimes need a longer dump hose, rather than longer flow and return hoses, the 2 x 5 metre lengths can be coupled together and added on to the existing dump hose. This gives flexibility without the need for a van full of hose.

Caution: longer hoses mean greater frictional losses, and so we suggest a maximum overall length of 12 metres per hose.

Q. Can you power flush a heating system with a thermal store type cylinder?

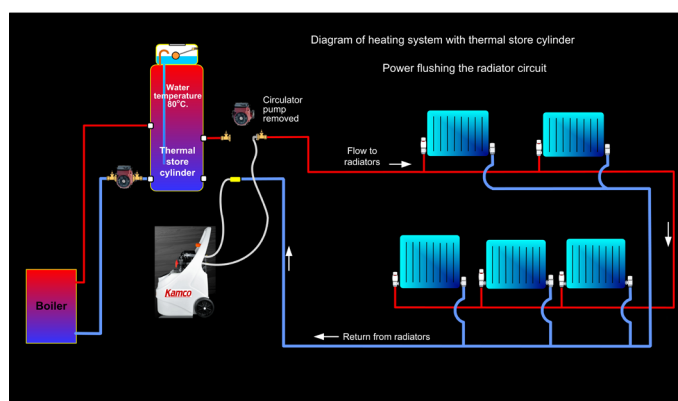

A. Yes. Our advice is to isolate the thermal store cylinder and flush the radiator and boiler circuits separately.

There are two reasons for this:

1. One cylinder manufacturer (Gledhill, though others may take a different view), advises that their cylinders shouldn't be connected on the positive side of a pump that may provide more than one bar pressure.

Although that level of pressure on the cylinder is unlikely to be present anyway, we advise a cautious approach.

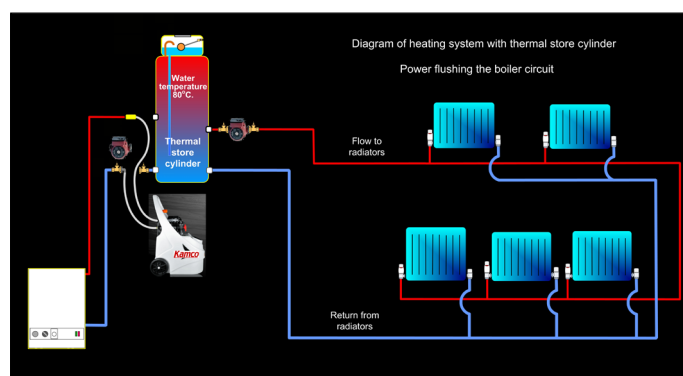

2. If you do include the thermal store in the power flushing circuit, then instead of pumping approximately 100 or less litres of water around, you'll be pumping around almost three times that, and so the vital overall flow rate will be much less than half – so not a good idea

if you want to clean a heating system.

3. Another way to power flush a heating system with a thermal store, again without including the cylinder and contents in the power flush, is to loop the cylinder out, so that the power flush pump is only connected in once, and the boiler and radiator circuits are flushed just as for a more conventional heating system.

See the following diagram for how to do this:

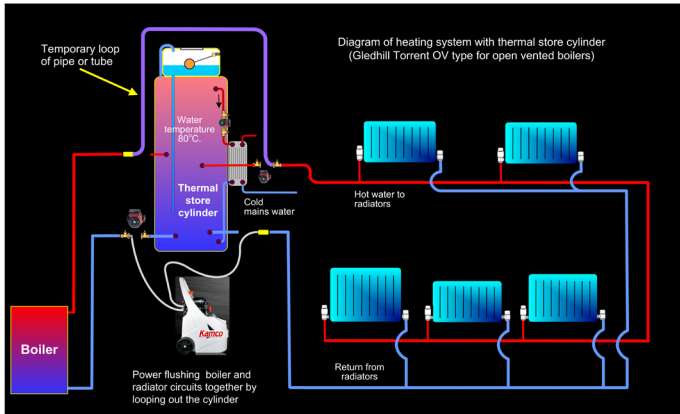

Things that might concern you

Q. Can you over pressurise a system, causing joints to leak?

A. No. All Kamco Clearflow pumps are centrifugal type pumps. What water they can't push through a system will simply re-circulate in the tank. Maximum pressure is less than two bars. It is the flow rate through a system that is important when power flushing.

Q. Any problems with thermostatic valves (TRVs)?

A. Generally, no, even with older TRV's which should only be fitted on the water inlet side of a radiator. Some thermostatic valves may stick down, or act as non return valves, so set them on 'MAX', and remove the valve heads. Push down on the sprung pin a few times to ensure that valve is fully open.

Things to check before you start

Q. The location where the cold feed and expansion pipes join a vented system is often a problem area with a lot of compacted debris. Can you tell if the cold feed pipe is blocked, without cutting into the pipe work?

A. Not conclusively, but try holding a small magnet against the outside of the copper pipe. Copper isn't magnetic, and so if you feel the magnet being pulled onto the pipe, that tells you that there's a lot of magnetic iron oxide based debris in there. If it's

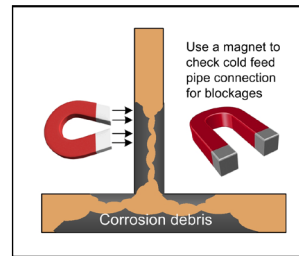

completely blocked you will have to cut the pipe work section out. Start cutting!

Q. Is there is another way to check if a cold feed pipe is blocked?

A. When starting to set up for a power flush, you'll normally cap off the cold feed and expansion pipes before anything else. Don't!

Just cap the expansion pipe only and leave the cold feed 'open'. Now get your power flushing pump connected in downstairs, with the isolating valves closed (as is normal until you are ready to start the power flush). Open the isolating valves without switching the pump on. Because the pump isn't running, theoretically, water should start draining from the system into your pump tank, under gravity.

If that doesn't happen, the reason will be a blocked cold feed pipe. Cut it out!

Chemicals to use

Q. Can I use Powerflush FX2 liquid on a system with aluminium radiators, or an aluminium heat exchanger such as found on condensing boilers?

A. No. We recommend that systems which include aluminium are treated with HYPER-FLUSH, ideally several days beforehand. You could then power flush the system with water alone, but for the best result we recommend that you use another pack of Hyper-Flush Concentrate as you carry out the power flush.

Q. Why can't I leave PowerFlush FX2 in a system, or pre-treat a system with FX2?

A. We advise against leaving PowerFlush FX2 in systems for a period of time BECAUSE it is a very powerful flushing chemical. A contributing factor to its performance is that it has a low pH, i.e. it is acidic. It does contain special inhibitors in the formulation to prevent corrosion of the system during the power flush, and these inhibitors are very effective.

However, if you left PowerFlush FX2 in a system for too long, then these special organic inhibitors would gradually break down, and become less effective, and some corrosion could take place.

This is not a problem during the course of a power flush, and if FX2 were left in a reasonably sound heating system

over night, we would not have any undue concerns, as long as it was carefully flushed out and Neutralising Crystals circulated through the system as is usual after using PowerFlush FX2.

Q. Do I really need to carry out the neutralising step after using PowerFlush FX2?

A. PowerFlush FX2 is based on phosphoric and citric acids. It is the low pH that gives it its “bite”, but of course it is necessary to ensure that the system water is back to pH 7 before completing the power flush, hence the neutralising step.

The PowerFlush FX2 formulation does include specific organic corrosion inhibitors that protect the metals of the heating system from attack during the Powerflush. However, if FX2 is left in the system, then with time and temperature these particular types of inhibitor break down. Without their protection, there would be some corrosion in the system. The likelihood is then that some while later the householder will call you and complain that they have to repeatedly bleed the radiators.

When engineers force debris and flushing chemicals out with the fresh water flow, they often believe that they have got all the acidic residue out – and they MIGHT be right – and the pH of a sample could be 7. The neutralising step (use of Neutralising Crystals) is a precaution in case there is a small amount of the FX2 still present in a nook or dead end pipe in the system. However, to get the maximum amount of debris out of a system, then PowerFlush FX2 is the way to go.

Q. What's the best chemical to use to flush a very old (30 years) heating system?

A. If you do decide to power flush a very old system, then it's important to carry out a survey beforehand - and you might change your mind subsequently!

We suggest Hyper-Flush for this application (and not PowerFlush FX2), because Hyper-Flush is a pH neutral product and is therefore less likely to be problematic than more aggressive chemicals. However, a 30 year old system has seen a lot of action, and we would suggest that the system be monitored carefully (= watched!) during the flush, whatever chemical you use. After 30 years there are probably radiators on the verge of failure, with only a veneer of debris preventing leakage from deep pits in corroded areas, and so your watchword is caution.

Q. How often should I check the corrosion inhibitor level, and how do I do it?

A. Whilst annual checking of inhibitor level is an excellent idea, actually doing this presents a problem to all heating engineers – you have to know what brand inhibitor is IN the system.



There is currently no test kit that will test for the presence of all inhibitors. The only safe thing is to drain down and start again if the brand inhibitor in a system is unknown. Kamco supply a test kit for SystemSafe-DM inhibitors, but it is important to note that

this test kit will only give the correct answer when used on a system containing Systemsafe DM.

The test is used to check the level of molybdate in the treated water. When Systemsafe is dosed at the ideal rate (impossible to guarantee in a real system of unknown volume of course), the optimum level is 100 parts per million for Systemsafe-DM. Other manufacturers' inhibitors may not use as much molybdate.



There are many different formulations, as most good and proven inhibitors will be a blend of up to a dozen components – some other inhibitors are often very basic, and very dilute - but they wouldn't pass the NSF/Buildcert inhibitor standard as Systemsafe DM does. It is important that the adhesive sticker supplied with the inhibitor is left attached to the system / boiler so that you know what inhibitor is in the system - and when it was added.

Q. Is it OK to mix inhibitors?

A. It's unlikely that mixing two inhibitors will do any harm, however most inhibitors are NOT all the same, as many people think. They are complex blends chosen for the abilities of individual components, but it's probably true to say some elements will be common.

There's a good chance that mixing two inhibitors will provide some degree of protection, but the ideal situation would be to drain down and only use one inhibitor in your system (a Buildcert approved one), to keep a system clean and long lasting.

Q. I often work on solid fuel fired boilers, which run at a higher temperature. Do I need to use a higher dosage rate of Systemsafe-DM?

A. No, Systemsafe-DM is also used on commercial systems operating at higher temperatures and it

performs well at the normal 0.5% dosage rate.

Firing the boiler during a power flush

Q. What about firing the boiler whilst carrying out a power flush?

A. By all means fire the boiler if you can – most chemical reactions will proceed faster with some heat, and also, when you come to put the full flow through each radiator in turn, it's useful to be able to feel whether the radiators are heating up across the whole area, or whether they have cold areas / panels. If they do, then you can give that radiator extra attention.

A CLEARFLOW pump will handle water temperatures above 70°C. We suggest firing the boiler for up to fifteen minutes, but there's no need to leave the boiler firing continuously.

If you do fire the boiler, remember that when you switch it off, the heat exchanger is still very hot, and continues transferring heat to the water circulating through it, and to the Clearflow pump. If you can't keep your hand on the pump tank, switch the boiler off.

If the boiler is non functional, or being replaced, then you won't be able to fire it anyway. If you're using a powerful chemical such as Powerflush FX2, you'll still get a good result even if you can't fire the boiler.



The alternative is to use a Kamco CombiMag Dual Digital combined power flushing magnet and heater, with a 3kW electric heater. This is inserted in one of the flow or return hoses.

Q. I have a combination boiler system to power flush but the boiler won't fire - what can I do?

A. Persuading a combination boiler to fire can be difficult because the low pressure limit switch senses a lack of pressure, and prevents the boiler from firing.

1. Remember that when your power flushing pump is connected into the heating, the maximum pressure you will find is at the output of the pump impellor, or in more practical terms, where your inlet hose connects into the system. From that point on the pressure is falling away throughout the system until the point where the return hoses drops the water back into your power flushing

pump tank, where the pressure is again zero.

If you're using a Kamco CP2 adapter to get connected into the heating system, your power flushing pump will be close to the boiler. Consequently if you set the flow reverser handle so that the water flow is immediately into the boiler rather than heading out into the radiator circuit, you'll be putting 1 bar+ pressure into the boiler and a combination boiler should fire up.

If you're not sure of the flow direction, just try with the flow reverser lever in either direction.

Note: the current Kamco CF40 Evolution and CF90 Quantum were 'tweaked' when we designed them to give extra pressure to help in this situation.

2. If the above doesn't work, try partially closing the Clearflow valve on the return side of your pump. By reducing the cross sectional area, you will automatically increase the pressure. Flow rate will be decreased, and so only leave the valve partially closed whilst firing the boiler. Once you have the water warm, shut off the boiler and fully open the Clearflow valve for the normal high flow rate needed for effective power flushing.

3. Here's another suggestion.

If you're flushing a combination boiler system that has been in use for a while (not a new boiler), and you have connected your power flushing pump into the system across the copper tails of a radiator, this should work. You could make up a temporary valved manifold and loop out the power flushing pump by closing the two valves in the flow and return hoses and opening the valve in the bypass between the hoses.

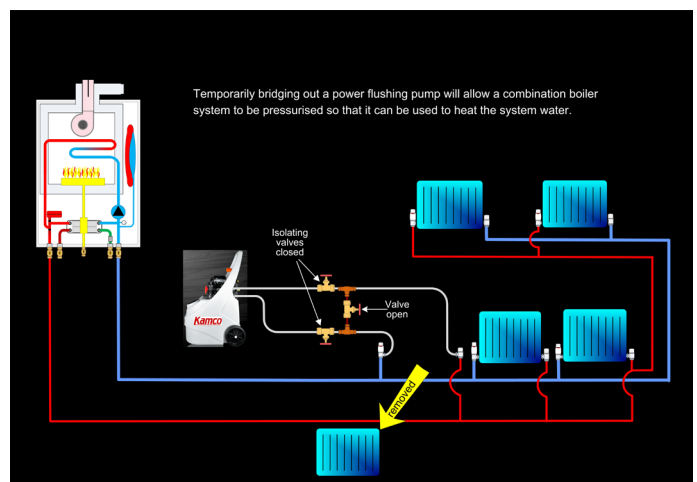

You now have a temporarily completely closed circuit, and so re-pressurise this the normal way, and then fire up the boiler until you have the system water good and hot. When you've got it up to temperature, shut off the boiler and use the valved manifold to put your power

flushing pump into circuit again.

4. This tip has been given to us by several of our customers now, and we can't guarantee that it will work on every combination boiler. With some boilers it is possible to fool the pressure sensor that stops the boiler firing, by linking out the low pressure switch. You'll need to take all the normal precautions when working with electricity (switch off first!), pull the wires off the water pressure sensor (two) & link them together. The boiler manufacturer technical department may be able to confirm the success of the link out. (Don't forget to restore the correct wiring after the power flush).

Other hot water issues

Q. Is it OK to dump very hot water from a heating system down a drain or sewer?

A. There is a Public Health Act Regulation of 1936, which states that water should not be discharged down a public sewer at a temperature greater than 43°C, but in reality this is unlikely to be a problem when power flushing. However, do consider the risk of cracking a toilet pan if you discharge very hot water into it when power flushing.

Q. Why shouldn't I use a CLEARFLOW pump with scalding hot water?

A. A Clearflow pump may need to be used with very strong chemicals, such as neat hydrochloric acid, when being used for descaling. To enable this, all wetted parts are either plastic, or are sleeved in plastic, and this imposes a temperature limitation.

At high temperatures the clear plastic flow and return hoses will become very flexible and may kink, so don't put scalding water through them. High temperature resistant hoses can be fitted to a Clearflow pump – but this type of plastic is not transparent, and you'd lose the advantage of being able to monitor water cleanliness by viewing the water as it travels through the pipes.

Remember that working with scalding water above 65°C poses risks to you!

Q. What do I do if I arrive at a house where the heating has been working, and the water temperature is above 70°C? Do I have to wait for the water to cool down?

A. No. Once you have connected the Clearflow power

flushing pump into the system, and connected all hoses, immediately set the valves into the dump mode (dump valve open), and then switch on. Run and dump for a couple of minutes, allowing cold water in to the system, before reverting to the normal flushing procedure.

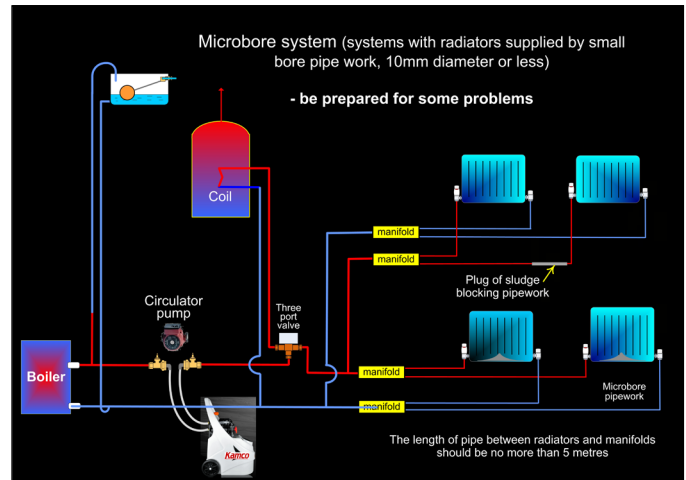

Tricky systems to power flush!

Q. Can you power flush a microbore system?

A. Yes, but connection of the Clearflow pump should be on to the circulator pump fittings, and not on to a radiator, otherwise the small bore tubing will drastically reduce the flow rate, and the system power flush will be less successful than normal. We advise using 5 litres of FX2 (instead of the usual 2.5 litres), to ensure the particles of debris are dispersed in as fine a form as possible.

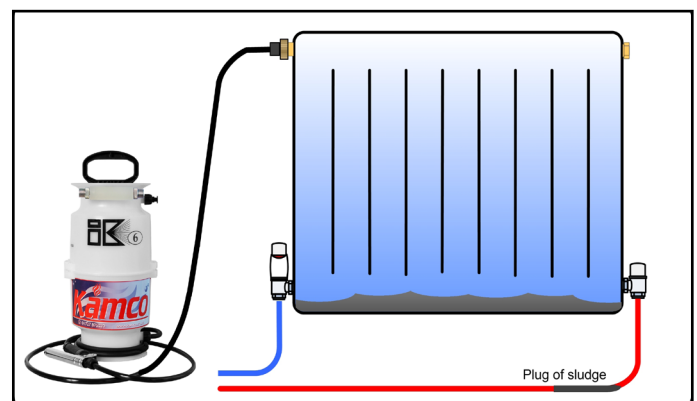

If you can't clear a radiator on a microbore system, it may be that a plug of sludge is blocking the narrow diameter pipework leading back to the manifold. If you have a Kamco Systemsure IK6 injector, the following can be worth trying to restore flow to the radiator.

Switch off and isolate the Clearflow pump. Close both valves on the problem radiator. Attach the injector unit to the air bleed screw fitting, and pump up the pressure

as high as possible.

Quickly open one radiator valve, and the air will often dislodge and move the semi-solid sludge along the pipe. Close the radiator valve, pump up the injector again, and open the other radiator valve. Finally, direct the full flow of the Clearflow through the radiator, with both valves open.

Q. Can you power flush a microbore system with double entry radiator valves?

A. Yes, but we suggest that you double the amount of FX2 to 5 litres. If the distributor spreader tube (which directs the incoming

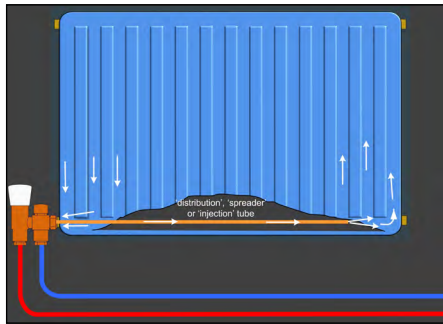

water towards the far side of the radiator) has broken away, so that the entrance and exit are effectively only 15-20mm apart, any flushing effect on that radiator will be minimal. Conversion to opposing inlet and outlet valves is a better long term proposition.

Q. Can you power flush a single pipe system?

A. If the radiators on a single pipe system have severe deposit build-ups, or cold panels, then the power flush is not likely to be successful. BS7593:2006 advises against power flushing a single pipe system. If you do take on such a system, improve the chances of success by pre-treating with two packs of HYPERFLUSH, and operate the flow reverser more often than usual whilst flushing individual radiators.

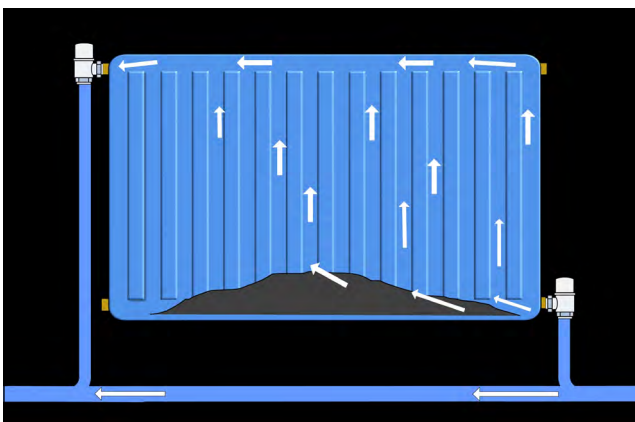

Can the CLEARFLOW be used on a system which has a Primatic type single feed cylinder?

A. It is necessary to disconnect or loop out the Primatic cylinder otherwise the high flow rate of the Clearflow pump will dislodge the air bubble in the cylinder, leading

to mixing of radiator and tap water.

The Primatic cylinder was usually gravity fed, with separate pumped flow and return piping to the radiators. Consequently, connecting your Clearflow onto the flow and return piping to the Primatic will not enable you to power flush the radiator circuit.

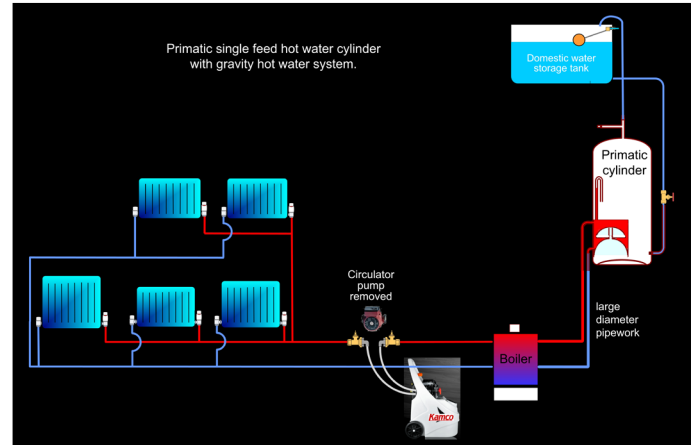

This would have to be power flushed separately, ideally by connecting across the system circulator pump connections.

N.B. Remember that Water Bye-laws prohibit the use of corrosion inhibitors (other than potable ones!) in systems with a Primatic cylinder, because of the risk of contaminating the domestic water supply.

Q. How do you recognise a Primatic cylinder?

A. The system itself should give you a clue. You won't find a feed and expansion tank, nor an expansion vessel anywhere else. Check the cylinder pipe connections closely. Conventional cylinders have male BSP connections on the cylinder for pipework to be connected to, whilst Primatics have female BSP connections going into the cylinder. If you're lucky, you'll see the word 'Primatic' stamped into the cylinder near the top.

Q. If the system is a gravity hot water system, with a separate non-pumped hot water circuit leading away from the boiler, won't that reduce the flow rate of water through the radiators when carrying out the individual radiator flush?

A. If you use the circulator pump adapter leads to connect across the circulator pump connections, or connect onto radiator tails, you shouldn't lose much of the flow through the large diameter pipework of the gravity hot water circuit. The boiler heat exchanger will act as a large diameter by-pass.

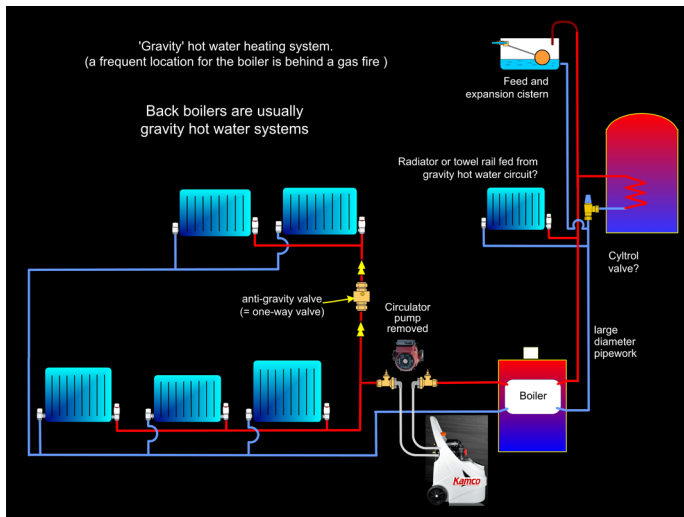

However, this will not clean the gravity hot water pipework. Some engineers will re-locate the Clearflow pump and connect it across the cold feed and expansion piping to force water through the gravity hot water circuit.

If there is one radiator on the gravity hot water circuit, as is sometimes the case, or a towel rail, you may be able to connect your Clearflow across the tails.

In an ideal world, you would disconnect the gravity hot water pipework at the boiler, and then power flush the hot water circuit separately – but this is far from easy in a back boiler fired gravity hot water system.

Q. Can you flush a very old system which has passivated steel or stainless steel piping, such as Truweld or Gecol?

A. Yes, you can, but we advise extreme caution, and you should always point out to the householder that you cannot guarantee that there will not be any leaks. These pipes were 'stop-gap' materials used during a period (late sixties/early seventies) when there was a copper shortage, and were not expected to have a very long life.

The passivated steel tube (similar dimensions to 15mm copper tube) was fabricated from sheet steel, folded over, seam welded and galvanised. Thirty years later it has generally corroded internally such that it is on borrowed time. Some engineers refer to this steel pipe work as "Birmingham" tube, as one source was a GKN company in the West Midlands. Look for tube of an aluminium / silver colour, and connected with soft soldered copper joints – and avoid it. Another clue is that it is magnetic – copper and stainless steel aren't.

The stainless steel tube supplied at that time was of a

low quality and is prone to pitting corrosion, and again is on borrowed time.

If in doubt, do not power flush the system. If you accept the job, use HyperFlush instead of PowerFlush FX2 – and always ask the householder to sign a disclaimer!

Q. Are there any other systems I should treat with caution?

A. Look out for low quality 'Type Z' 15mm copper tubing of continental origin, also supplied at the time of copper shortages. It was prone to pitting, and had a very thin wall thickness, such that it could not be bent. You can recognise it because the manufacturers kindly printed a red line along it. Another clue will be the lack of any bends (only joints) in the copper piping.

Q. Can you power flush systems with old plastic piping (PEX), which didn't have the 'barrier' included?

A. You can flush such systems exactly as for any other system, BUT you'll probably find they are very heavily sludged. Most plastic piping now includes a barrier layer, to stop air diffusing through the wall of the pipe, and only 'barrier' type pipe should be used for heating systems.

The water in pipe without a barrier layer will always be more oxygenated (=more conducive to corrosion) and therefore systems with the non barrier pipe can be expected to corrode faster even with a good corrosion inhibitor present. The inhibitor level should be checked every six months rather than annually.

Unless the system is re-piped it is probable that it will need to be power flushed every few years, and it is prudent to warn the householder that this is the case.

Other systems?

Q. Can you power flush a system with plastic piping, such as Hep20?

A. Yes you can. PowerFlush FX2 liquid and HyperFlush can be used on plastic pipework systems, and will not damage either the pipework, or the 'O' ring materials.

Q. Can you power flush under floor heating systems?

A. Yes you can. Underfloor heating systems are piped in plastic tubing, and either FX2 liquid or HyperFlush can be used on these systems, and will not damage either the pipework, or the 'O' ring materials.

Q. How do I go about flushing underfloor system?

Where do I connect my Clearflow pump?

A. The first question we usually ask is “Are you sure the system needs flushing?”, If the whole house has underfloor heating, with no radiators or towel rails, where might the debris have come from?

Often heating circuits are mixed systems, perhaps with radiators upstairs where it is most difficult to convert to underfloor heating, and with underfloor heating plastic pipework downstairs, and it is corrosion debris from the upstairs radiators that is accumulating in the under floor circuits.

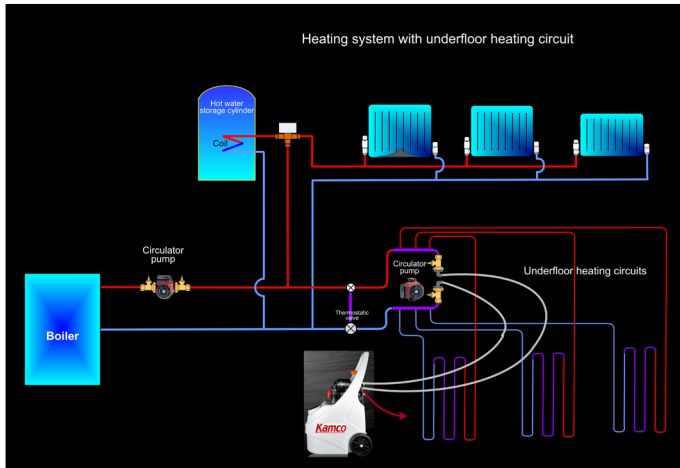

Underfloor circuits usually have a separate circulation pump. We advise that first the downstairs underfloor circuit is isolated and the rest of the heating system then flushed conventionally. Once water there is fresh and clear, isolate the upstairs circuits, and use a Kamco CP2 pump head adapter to connect on to the underfloor heating system circulator pump. Flush each underfloor loop one at a time using the individual flow control valves on each circuit, just as you would if you were flushing radiators.

N.B. We HAVE encountered systems which are totally underfloor heating and which have flow problems as a result of debris. Generally this is organic, bacterial matter which has occurred as a result of degradation of glycol based antifreeze type products in the water. The temperature of underfloor circuits needs to be much lower than conventional central heating circuits (in order to prevent householders ‘tap dancing’ on very hot floors), and this lower temperature is very conducive to bacterial growth.

Q. If I have an underfloor heating system with bacterial growth, how can I remove it, and prevent future problems?

A. You need a specialist cleaner to break down and

remove bacterial matter in heating systems. Kamco Systemsafe-Bio is the product to use. Circulate it through the heating system for at least 4 hours if using the system circulator pump, or up to 24 hours if the system is heavily fouled. You can reduce this time by 75% if using a power flushing pump.

Once the system is clean, add further Systemsafe-Bio at a dosage rate of 0.25% to prevent future contamination, together with the correct dosage rate of Systemsafe-DM corrosion and scale inhibitor.

Q. How can you work out how much water is present in an underfloor system, and how much chemical is needed?

A. If the system installer left notes on how much pipe was used under the floor, you could calculate it - but that’s unlikely. However, there is a rule of thumb guide with underfloor heating that if you multiply the boiler output (in kW) by 23, you’ll have a fair guide to the water content in litres. Thereafter, calculate how much PowerFlush FX2 would be needed by multiplying the system water volume by 2.5%, or multiply by 0.5% if you are using HyperFlush.

For countryfolk

Q. Can I power flush a system in a house which does not have mains drainage, but only a septic tank?

A. You can power flush the heating system of such a dwelling, but it requires care and consideration beforehand. The only alternative to a power flush would be a complete and costly system re-build.

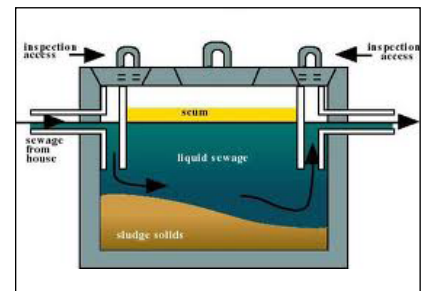

Also remember that a power flush uses several hundreds of litres of water, depending on the size of the system, and it would be a good precaution if the householder has the septic tank serviced/ emptied in advance of the date of the power flush.

The main consideration is what chemical to use, if any, and how to safely dispose of it and of the waste water generated during a power flush.

What flushing chemical should you use?

The possibilities are:

1. 'NONE', accepting that you won't be able to carry out a very efficient power flush but you won't have to worry about the effects of any chemical on the bacteria in the septic tank.
2. Use PowerFlush FX2, carrying out the normal flushing procedure as usual until you have put the full flow through each radiator in turn. Instead of then commencing to dump on each radiator in turn, carefully start adding Neutralising Crystals into the power flushing tank to neutralise all the acidity before you begin to dump on each radiator. Check the pH regularly until the water is back up to a pH of 7.

What about the contaminated waste water, containing quantities of iron oxides?

You can minimise the amount of corrosion debris going down the drain by using a Combimag power flushing filter (two would be better!), and we strongly recommend that any power flush on a septic tank dwelling should use a CombiMag.



If the householder has concerns about the debris entering the septic tank, then consider taking a 200 litre barrel on site, and using that to take the waste water away to where it can be disposed of down a foul water drain.

It's very probable that the total amount of water used during the power flush will exceed 200 litres, and so to minimise the amount of water to be taken off site, consider only pumping into the barrel the first minutes worth of dumped water from each radiator, as you commence the 'dump on each radiator' procedure. This obviously will be the most contaminated water.

Something puzzling is happening here!

Q. What happens if there is no apparent flow through the CLEARFLOW unit when the flow reverser handle is in one particular direction when I'm working on the upstairs radiators?

A. If the system is a gravity hot water system, there is probably an anti gravity / non return valve in the radiator circuit. If the non return valve is accessible, either loop it out, or remove the plunger so that it doesn't prevent the flow of water in one direction. If you can't find the non

return valve (which is very probable), the flow reverser lever must be left in one direction.

Q. I've connected my Clearflow into a heating system, made it into a sealed system, opened the isolating valves, and switched on. The pump appears to be working fine, but the water level in the Clearflow tank is overflowing without the mains water inlet valve even being open. What's happening? Is there something wrong with the Clearflow pump?

A. The answer is usually NO.

A1. This situation often occurs when for whatever reason (perhaps a zone valve jammed by hard scale broken loose from elsewhere in system, or complete blockage in part of system, or even a sticking non-return / check valve) your power flushing pump is running / rotating but is not actually able to pump the water from its tank out into the system i.e. no water is actually leaving the tank. However, some system water will drain back down into the tank through the 'return' hose under gravity, and so the water level starts to rise.

(This occurs most often in a gravity hot water system, or one that has at some time been converted from such a system.) The solution is not always obvious, but you need to check for any possible reason why the system is choking off pump flow.

If you can't locate the problem, you'll have to point the flow reverser lever in the opposite direction, and leave it there.

A2. It's less likely, but if it is a sealed system, there may be an automatic pressurisation unit (sometimes known as an autofiller) connected to the system, to maintain the required pressure.

Switch it off, or it will be continually introducing more water into the system to try to top up the pressure, and as a side effect forcing water against the direction of flow you need for a successful power flush.

Q. On some systems, when I am dumping the water from the system, and I have used the boiler to heat the water during the power flush, I notice that the radiators are cold at the bottom, and warm at the top. What's happening?

A. A Clearflow pump circulates the water through a system much faster than the standard system pump, and it is the cool fresh water speeding straight across the base of the radiator that you can feel.

Eventually the warmer water will be swept from the radiator, but you can speed it up by introducing some air into the top, of the radiator to force the water level down, using a Kamco Systemsure injector.

Now put the full flow through each radiator in turn, and watch the water discolour again as more debris is brought into suspension.

Q. Do I need to carry out a separate dumping procedure on each radiator?

A. Yes, but don't do so immediately after adding the flushing chemical. If you do, you'll be dumping your flushing chemical straight down the drain, and will have to keep adding more as you work your way around the house.

Whilst we think that this is an excellent idea from a chemical suppliers' point of view, it isn't generally necessary, as loosened debris takes many hours to settle or compact, and will have been purged from the system long before this could happen.

Put the full flow, with chemical treatment, through each individual radiator in turn. Only then, commence dumping, working your way round the house, ensuring the full flow through each radiator individually as you dump, by closing off all other radiators.

Operational problems

Q. What do I do if the mains water supply is very poor, and can't replenish the CLEARFLOW tank fast enough whilst dumping? Should I part close the dump valve?

A. Don't partially close the dump valve if the water level in the tank keeps falling. Wait until the water level is about 12 cm from the bottom, close the dump valve and re-open the isolating valve on that side (i.e. re-establish circulation through the system).

However, leave the water inlet tap OPEN, and allow the tank to fill until the level is close to maximum.

As soon as the water level reaches maximum, again switch into dumping mode, until the water level falls to 12 cm from the bottom, and then repeat the exercise until dump water finally runs clear.

This method ensures that the water is always moving vigorously throughout the system, ensuring that debris is kept moving, in suspension.

Q. What can I do if I am working on a radiator with such a severe build-up of corrosion debris that I am struggling to clear it all?

A. Difficult radiators such as this will often respond to use of the Radhammer vibrator device, also supplied by

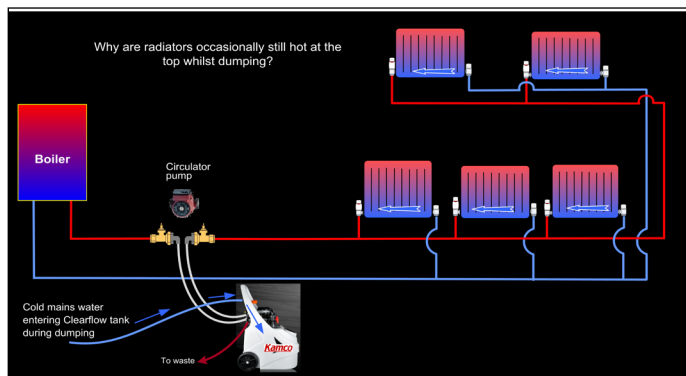

Q. On some systems, after I have fired the boiler to heat the system once I have added the flushing chemical, I notice that the radiators are hot at the bottom, but still cold at the top. Why?

A. The reason is the same as for the previous question. A Clearflow pump circulates the water through a system much faster than the standard system pump, and the heated water is speeding across the base of the radiator rather than circulating throughout the whole radiator. Given time the heat will spread up the radiator, but try reversing the flow a few times to speed up the process.

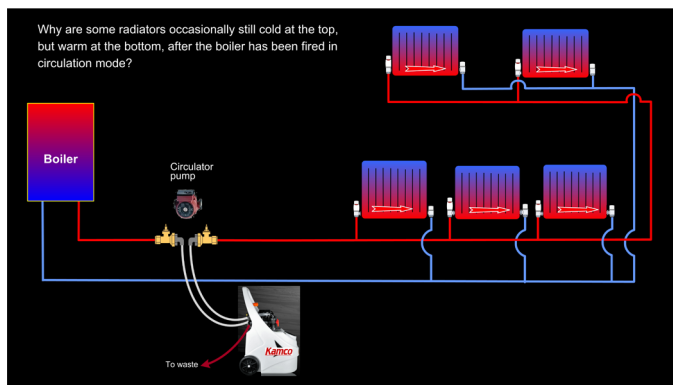

Cutting corners?

Q. Is it necessary to bleed radiators after a power flush?

A. Yes. However, the amount of air in the radiators is usually small. If you keep the water level in the Clearflow tank at least 15 cm (6") above the minimum, you'll minimise the air to be bled from radiators.

Q. Is it really necessary to carry out the individual radiator flushing procedure?

A. Yes. You can prove it for yourself by flushing a system without putting the full flow through each radiator in turn, and then dumping until the waste water is clear.

Kamco. This device fits into the chuck of an SDS drill which has been set to 'hammer only', and is applied firmly to problem areas of the radiator. The high frequency vibration will loosen debris that will not respond to other cleansing methods.



Q. I've tried everything with a severely choked radiator - full flow, heated the water, vibrated with a RadHammer and still there's a cold area. What else can I do?

A. Try this:- With the full pump flow on the problem radiator, use a Kamco Systemsure IK6 chemical injector to blast air into the top of the radiator using an IK6 air bleed valve adaptor.

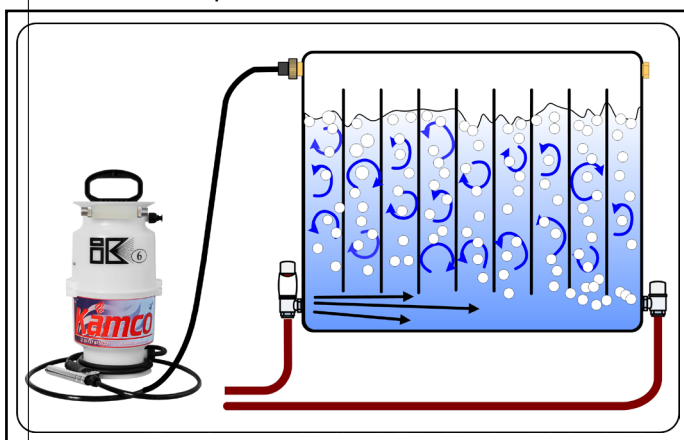

You'll get a huge amount of turbulent agitation in the radiator which will create the optimum condition for mobilising debris. Then switch off your pump and immediately inject more air into the radiator, to depress the water level to about half way down the radiator. Switch on your power flushing pump again. The air in the top of the radiator will prevent any water from passing along the top channel, and the full force of the water will slam into the usual debris build up area along the base of the radiator, giving you a much better chance of removing it.

How can I check that I've thoroughly cleaned the system?

Q. Is there a better way than a simple visual inspection to ensure that the system water is really clean?

A. Yes. A simple way to check that the water is chemically as clean as mains tap water is to take a sample both of tap water, and of the water exiting from the dump hose, and to take measurements with a Total Dissolved Solids



(TDS) electronic meter. The dump water reading should be as close to the mains water reading as possible, and ideally within 5-10% of the reading obtained for tap water.

Another method is to use a turbidity tube to give a reading of suspended particulate matter in the dump water. The turbidity tube is a long clear tube, with a marker on the base. Turbidity is determined by the degree of obscuration of the marker when looking along the length of the tube containing system water.



What NOT to do

Q. Can the CLEARFLOW pump be set up and left unattended whilst I carry out another job elsewhere?

A. No, it is unwise to leave any powered equipment unsupervised in a domestic environment, with runs of hose and power cable which could be in close proximity to householders, children, and pets.

Should there be an electricity power cut, the Clearflow would stop pumping, and water would drain down into the tank through the return hose, causing it to overflow.

You will be using powerful flushing chemicals, and as for all chemical products, they should be treated with respect and kept away from children.

Q. Are there any possible problems when dumping water into a toilet pan?

A. Yes, and the most likely one is the dump hose sliding out of the toilet pan when you start dumping, and flooding the bathroom, so trap it in place with the toilet seat before you start work. Better still, use a piece of cord to tie the dump hose to the seat hinge. Also, consider whether the porcelain might be stained by the discoloured dump water.

Saving time

Q. How can I reduce the time taken to power flush a heating system?

A. In order to clean a system effectively you must carry out the full procedure, including putting the full flow through all radiators and sections of the heating system. However, you can reduce the overall procedure time if you use an inline magnetic power flushing filter, such as the Kamco CombiMag filter.

This is installed between the heating system and the power flushing pump, and extracts magnetite (the major corrosion constituent) from the circulating water, which consequently clears much faster, reducing the time taken to obtain clear fresh water throughout the system. The volume of water required to power flush a system is also significantly reduced.

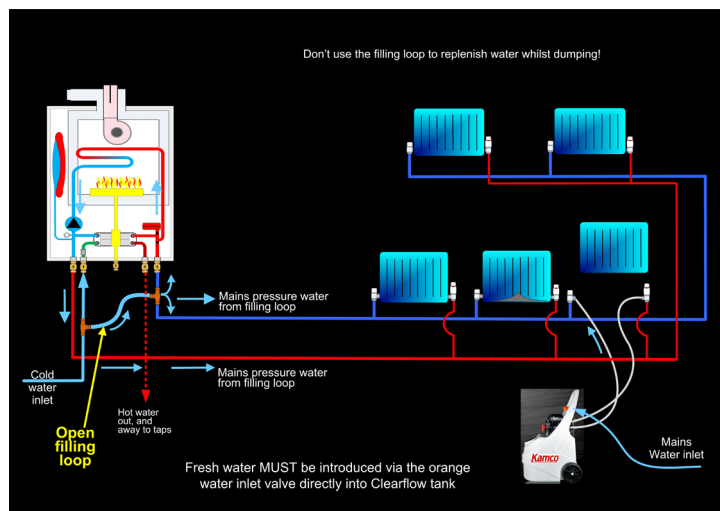
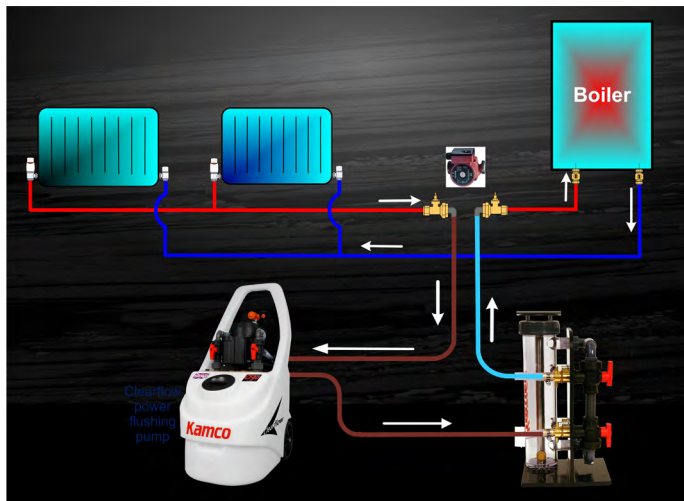

Miscellaneous

Q. Can you use the pump to add corrosion inhibitor to a system?

A. Yes, it's a good way to get corrosion inhibitor rapidly into a system and thoroughly dispersed. Before disconnecting the Clearflow pump, lower the water level in the tank to just above the minimum level, close the dump valve, and add the inhibitor into the Clearflow tank. Allow circulation through the system for ten minutes before finally disconnecting.

Part L: 2006 of the Building Regulations now require that a system is treated with corrosion inhibitor. Benchmark members specify the use of an inhibitor which has passed the NSF/Buildcert performance standard. Suitable inhibitors, such as Kamco Systemsafe-DM, will display the Buildcert logo, so check for this to ensure that you use an inhibitor that has been performance tested.

Q. When flushing a system with a combination boiler fitted with a filling loop, do I need to connect a water supply hose to the orange Clearflow water inlet valve? Can't I just run water in through the filling loop during dumping?

A. No. It is important that fresh water is fed into the system via the Clearflow tank. Introducing the water through a filling loop elsewhere will destroy the high velocity mono-directional flow and hence the efficiency of the whole power flushing process.

Q. I'm working on a house with a water softener installed on the water supply. Is there any problem if I fill the system with artificially softened water after the power flush? Can Systemsafe-DM inhibitor be used?

A. Systemsafe-DM can be used for systems containing artificially softened water, and will give a significant degree of protection. However, you should be aware that by using artificially softened water you are risking a higher level of corrosion.

Artificially softened water is inherently more corrosive than either hard or naturally soft water, for good sound chemical reasons, hence ANY inhibitor will have to work harder, and pitting of aluminium is always a possibility. Any new water softener installation complying with guidelines will have a by-pass. We suggest that you by-pass the water softener whilst filling the system, then re-open the by-pass and enjoy the benefits of artificially softened water elsewhere in the house. Prudent boiler manufacturers take the view that if you can use water that is less aggressive, then you should.

Background information:

BEAMA Water Treatment is a trade association to which the market leading inhibitor manufacturer members (including Kamco) belong, and BEAMA members advise customers and installers in the supply chain against using softened water in the primary side of heating systems. Although a good corrosion inhibitor can minimise corrosion problems, BEAMA statistics show that 74% of sampled systems have inadequate/no inhibitor or are under-dosed, and such systems when filled with artificially softened water are at considerable risk.

Q. Baxi say don't power flush a Solo 2- why is that?

A. Baxi had a kettling problem with heat exchangers in

early models. They later supplied a rubber 'kebab' in the heat exchanger, the function of which was to cause turbulence to prevent localised boiling, BUT power flushing can dislodge the kebab such that it blocks the exit, and so if you need to tackle such a system, you'll have to isolate the boiler.

Servicing

Q. Where can I get my Kamco pump serviced?

A. At Kamco. We have a service department at our St Albans works where we build the pumps. We have all spares in stock, and can service any pump that we've sold since 1986.

We don't have service engineers on the road as the volume of repairs doesn't warrant that. We carry out repairs at St Albans, and ensure that we turn them around fast.

Upon receipt of a pump we strip and performance check it, and then call you to advise what we think needs doing, and the cost.



It is unlikely that a repair will take more than two hours labour. The cost of parts needs to be added, but unless something drastic has happened to a pump, the cost of a repair is always far less than the cost of replacing it.

We only need the pump on its tank to be returned (no hoses required) and we advise that the pump be very well packed, particularly around and ABOVE the motor / handle to prevent parcels carriers from destroying the pump.

If you don't use a parcels carrier service yourself, then we can arrange for TNT to uplift it and return it to our works. They send a specific vehicle out to do the uplift, and charge £25 for this. On the upside, they are quick and quite efficient. If you would like a Kamco pump serviced, either send it to the service department at our works address, or, if you prefer, pack the pump and then

call us to arrange collection.

Will power flushing damage the system?

Q. Will power flushing cause damage to a heating system?

A. It is rare for a heating system to experience leaks after the power flushing process. However, experienced heating engineers will probably explain the following to householders:-

Sludge and debris are present as a result of corrosion over a long period of time.

The power flushing process will cure most circulation problems, but cannot undo the corrosion and gradual decay of heating system components that has led to the need to power flush the system.

Occasionally some systems may have radiators with localised deep corrosion pits, with only a scab of rust preventing the system water from leaking out. The vigorous flow rate required to mobilise sludge and deposits may dislodge such a scab, leading to a leak from the radiator during the flushing process.

The advanced stage of corrosion required for such a situation means that the leak would occur imminently even without a power flush. If it should be brought forward slightly by the flushing process, then it is better that it occurs whilst a heating engineer is present to remedy the problem, rather than for it to arise over a weekend or whilst the house is unoccupied.

Kamco power flushing chemicals are comprehensively inhibited, so that they do not affect the metals from which heating systems are constructed.

They are formulated so that they loosen and dissolve the corrosion products that cause boiler noise and circulation problems, enabling the power flushing process to power them out of the heating system.

It is important after the flushing process to add a good quality inhibitor such as SYSTEMSAFE-DM to the heating system to prevent future decay. Part L: 2006 regulations now make the addition of a chemical corrosion inhibitor mandatory.

Guaranteed cleanliness?

Q. Can you guarantee to get a system clean with a power flush?

A. Although an engineer may power flush a system until the water exiting the dump hose is clear, and will usually carry out tests to check this, it is not uncommon for a system with relatively clear water to still have some compacted debris in the lower parts of the system / radiators. This may later break loose and discolour the water, although it is rare that it is in sufficient quantity to cause problems.

Engineers occasionally find a layer of very hard black iron oxide corrosion debris (magnetite) in the form of scale on the internal surfaces of pipe work, and which has developed over many years. Sometimes this hard scale will not be removed by a power flush, but fortunately the same adhesive nature that makes it difficult to remove also tends to keep it bonded to the pipe where it does no harm.

How long will a power flush last?

Q. Once I have a power flushed a house, will it require flushing again after a few years?

A. We would not expect a well designed system without obvious problems to require a further powerflush in less than five years, and generally for much longer than that if the system has been properly treated with a Buildcert approved inhibitor. However, there are too many variables and unknowns for us to give specific advice.